

# SSB1378A 规格书 蓝牙5.2 模组 SSB1378A Datasheet BLE 5.2 Module

文档信息 Document information	
标题 Title	SSB1378A 规格书 蓝牙5.2 模组 SSB1378A Datasheet BLE 5.2 Module
文档类型 Document type	规格书 Datasheet
文档编号 Document number	SS-23030223
版本及日期 Version and date	V1.04                      28-Dec-2020
秘密等级 Disclosure restriction	公开 Public

## 版本历史 Revision History

版本 Revision	描述 Description	审查 Approved	日期 Date
V1.01	初始发布 Initial Release	Roman	2021.12.23
V1.02	UART 串口由 TX_PB2,RX_PD1 更正为 TX_PB1,RX_PB2/ UART serial ports changed from TX_PB2,RX_PD1 to TX_PB1,RX_PB2	Roman	2022.1.18
V1.03	更新管脚定义/ Update the Pinout Description	Roman	2022.3.11
V1.04	添加模组参数/Add module parameters	Shaly	2022.3.28

Singsun保留本文档及本文档所包含的信息的所有权利。Singsun拥有本文档所述的产品、名称、标识和设计的全部知识产权。严禁没有征得 Singsun的许可的情况下复制、使用、修改或向第三方披露本文档的全部或部分内容。

Singsun对本文档所包含的信息的使用不承担任何责任。没有明示或暗示的保证，包括但不限于关于信息的准确性、正确性、可靠性和适用性。Singsun可以随时修订这个文档。

Singsun reserves all rights to this document and the information contained herein. Products, names, logos and designs described herein may in whole or in part be subject to intellectual property rights. Reproduction, use, modification or disclosure to third parties of this document or any part thereof without the express permission of Singsun is strictly prohibited.

The information contained herein is provided "as is" and Singsun assumes no liability for the use of the information. No warranty, either express or implied, is given, including but not limited, with respect to the accuracy, correctness, reliability and fitness for a particular purpose of the information. This document may be revised by Singsun at any time.

## 目录 Contents

1. 简介 Brief Introduction .....	4
2. 特点 Features .....	4
3. 应用场景 Applications .....	5
4. 应用框图 Application Block Diagram .....	6
5. 管脚定义 Pinout Description .....	7
6. 接口简介 Interfaces Introduction .....	9
6.1 数字输入输出引脚 Digital I/Os .....	9
6.2 通用同步/异步接收机/发射机 Universal Synchronous/Asynchronous Receiver/Transmitter ....	11
6.3 两线双向通信接口（兼容 I2C）Two-wire Interface (I2C Compatible) .....	11
6.4 程序烧录口 Flash Program I/Os .....	12
6.5 脉冲密度调制接口 Pulse Density Modulation(PDM) Interface .....	12
6.6 模数转换 Analog to Digital Converter .....	12
7. 模组参数 Module Specifications .....	13
8. 参考设计原理图 Reference Schematic .....	16
9. PCB 设计参考 PCB Design Guide .....	18
10. 生产过程推荐 Manufacturing Process Recommendations .....	19
10. 包装信息 Packaging Specification .....	20
12. 订购信息 Ordering Information .....	20
13. 联系信息 Contact Information .....	21

## 1. 简介 Brief Introduction

SSB1378A是一个高度集成的蓝牙 5.2 模组，可用在 2.4GHz ISM 频段内做高速率、短距离无线通信。模组基于 EFR32BG22 蓝牙无线收发芯片，内部集成 32 位 ARM Cortex-M33 处理器，主频 76.8MHz，同时内置 32kB RAM 和 512kB Flash，支持模拟或者数字外设。SSB1378A提供了低功耗高性价比的蓝牙传输和 AOA 定位应用。

The SSB1378A is a highly integrated BLE 5.2 module, designed for high data rate, short-range wireless communication in the 2.4GHz ISM band. The module is based on EFR32BG22 radio transceiver IC, which integrates a 32 bit ARM Cortex-M33 76.8MHz CPU, 32kB Data RAM, 512kB Flash memory and analog and digital peripherals. The SSB1378A provides a low power and high cost-effective BLE solution for wireless transmission and AOA positioning.

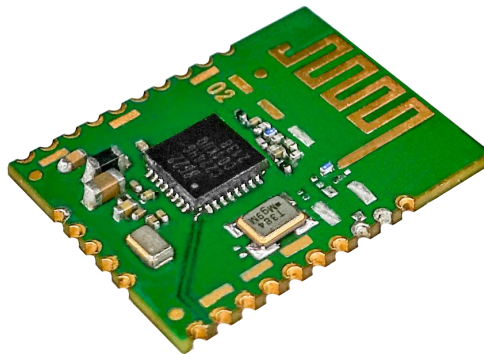

Figure 1: SSB1378A Without Shielding

## 2. 特点 Features

- ◆ 主控芯片/ Main Chip: SILICON LABS EFR32BG22
- ◆ 蓝牙低功耗 5.2 协议/ BLE® 5.2 protocol
- ◆ 支持蓝牙到达角、发射角定位/ Support BLE AOA/AOD positioning
- ◆ 支持 BLE 全速率模式/ Supported BLE all data rates : 125kbps/250kbps/500kbps/1Mbps/2Mbps
- ◆ 优秀的射频性能/Superior Radio Performance: TX Power 6dBm / RX sensitivity -106.7dBm@125kbps GFSK
- ◆ 极低功耗/ Ultra Low Power consumption: TX 4.1mA@0dBm, RX 3.6mA@1Mbps, Sleep current<1.8uA
- ◆ 4 路 16 位定时器+1 路 32 位 RTC 定时器+1 路 24 位低功耗波形发生定时器/  
4x16bit timers+1x32bit RTC timer+1\*24bit Low Energy Timer for waveform generation

- ◆ 12 位 1M 采样率 SAR 型 ADC/ 12-bit 1Msps SAR ADC
- ◆ 丰富的外设接口/ Abundance of peripheral interface:  
2\*USART(UART/ SPI/ SmartCard-ISO7816/ IrDA/ I2S), 2\*I2C, PDM for Digital Microphone, 12\*PRS
- ◆ 硬件加密/ HW encryption: AES 128/256,SHA-1,SHA-2,ECC(up to 256bit),ECDSA(up to 256bit) and ECDH
- ◆ 兼容 ROHS (无铅) / ROHS compliance (Lead-free)

### 3. 应用场景 Applications

- ◆ 蓝牙 AOA 定位基站/信标 BLE AOA Anchor/Beacons
- ◆ 蓝牙 5.2 无线麦克风 BLE 5.2 wireless microphone
- ◆ 电脑输入输出外设 Computer peripherals and I/O devices
  - 鼠标 Mouse
  - 键盘 Keyboard
  - 多点触控板 Multi-touch trackpad
- ◆ 交互式娱乐设备 Interactive entertainment devices
  - 遥控器 Remote controller
  - 3D 眼镜 3D Glasses
  - 游戏远程控制器 Gaming remote controller
- ◆ 个人局域网 Personal Area Networks
  - 健康传感及监控设备 Health/fitness sensor and monitor devices
  - 医疗设备 Medical devices
  - 遥控钥匙+手表手环 Key-fobs + wrist watches
- ◆ 遥控玩具 Remote control toys
- ◆ 彩色遥控 LED 灯 Colourful LED Control
- ◆ 楼宇自动化 Building automation
- ◆ 无线传感器网络 Wireless sensor networks.
- ◆ 资产追踪 Asset tracking.

## 4. 应用框图 Application Block Diagram

SSB1378A 模组内部集成 1.8V DCDC，IO 电平默认使用 3.3V，可以直接用纽扣电池供电。

SSB1378A module integrates 1.8V DCDC, and the IO voltage is 3.3V by default.

It can be powered by coin battery.

默认贴 32.768kHz 晶体和 32MHz 晶体。

The 32.768kHz and 32MHz crystal is default mounted.

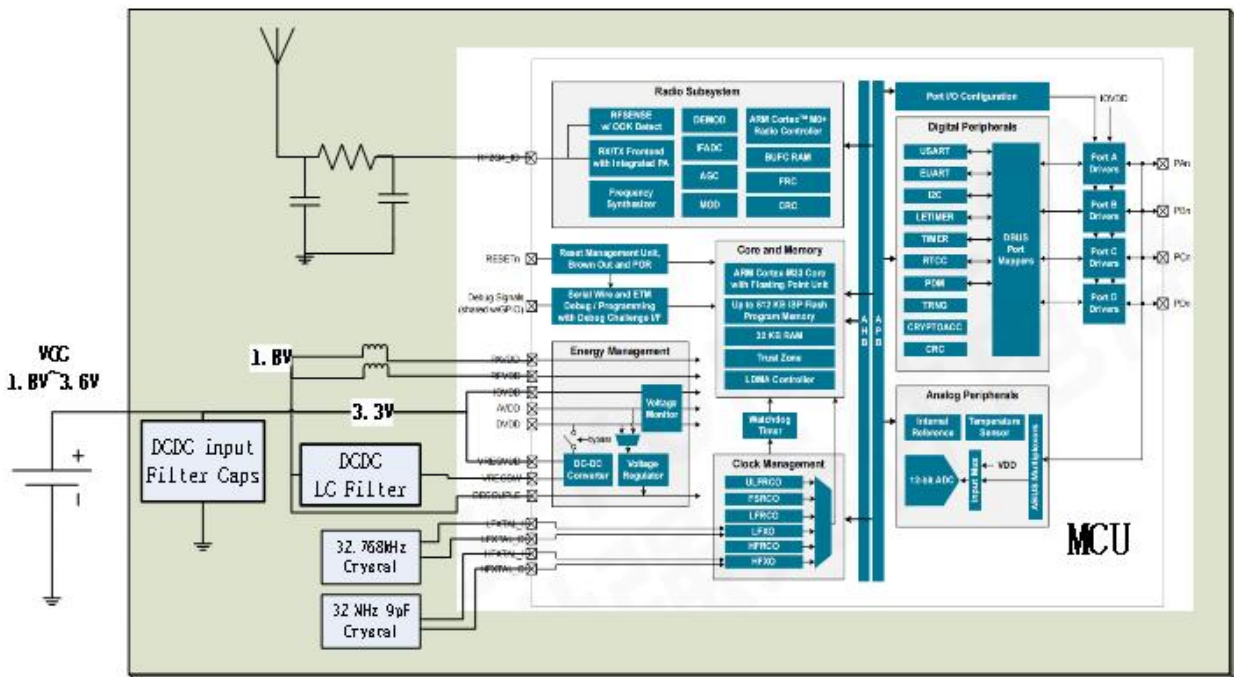

Figure 4: SSB1378A Block Diagram

## 5. 管脚定义 Pinout Description

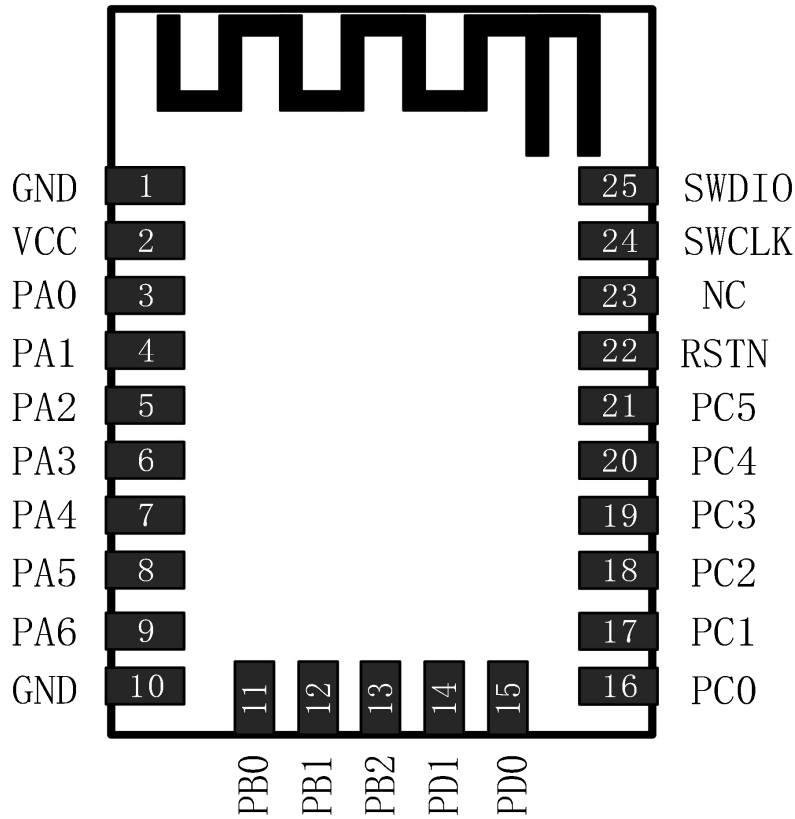

Figure 5: SSB1378A Module Pinout

引脚 Pin No.	引脚名称 Pin Name	引脚类型 Pin type	备注 Remark
1	GND	Ground	接地焊盘 Ground PAD
2	VCC	Power Supply	1.8~3.6V 电源供电脚,使用一个 10uF 和一个 0.1uF 滤波电容靠近 1 脚和 2 脚 1.8V to 3.6V power supply,Place a 10uF and a 0.1uF filter capacitors near pin1 and pin2
3	PA0	Digital I/O	通用输入/输出端口 General input/output port
4	PA1	Digital I/O	复用输入/输出端口 Multiplexed general input/output port 与 SWCLK 共用 GPIO Internally shared with SWCLK
5	PA2	Digital I/O	复用输入/输出端口 Multiplexed general input/output port 与 SWDIO 共用 GPIO Internally shared with SWDIO
6	PA3	Digital I/O; Analog input	通用输入/输出端口 General input/output port;

7	PA4	Digital I/O; Analog input	通用输入/输出端口 General input/output port;
8	PA5	Digital I/O; Analog input	通用输入/输出端口 General input/output port;
9	PA6	Digital I/O; Analog input	通用输入/输出端口 General input/output port;
10	GND	Ground	接地焊盘 Ground PAD
11	PB0	Digital I/O; Analog input	通用输入/输出端口 General input/output port;
12	PB1	Digital I/O; Analog input	通用输入/输出端口 General input/output port; 默认作为串口通信发射 Default TX for UART communication
13	PB2	Digital I/O	通用输入/输出端口 General input/output port 默认作为串口通信接收 Default RX for UART communication
14	PD1	Digital I/O	默认接 32.768kHz 晶体输入 XTALIN 通用输入/输出端口 General input/output port
15	PD0	Digital I/O	默认接 32.768kHz 晶体输出 XTALOUT 通用输入/输出端口 General input/output port
16	PC0	Digital I/O	通用输入/输出端口 General input/output port
17	PC1	Digital I/O	通用输入/输出端口 General input/output port
18	PC2	Digital I/O	通用输入/输出端口 General input/output port
19	PC3	Digital I/O	通用输入/输出端口 General input/output port
20	PC4	Digital I/O	通用输入/输出端口 General input/output port
21	PC5	Digital I/O	通用输入/输出端口 General input/output port
22	RSTN	System Reset (Active low)	低有效复位 Low efficient reset
23	NC	Not Connect	不接(模组型号区分脚: 采用 IPEX 时接地, 采用板载天线时悬空); Not connect (Module type difference: Low for IPEX antenna, NC for PCB antenna)
24	SWDCLK	Hardware debug and Flash program I/O	串行总线调试时钟输入口 SWD(Serial wire debug) clock input
25	SWDIO	Hardware Debug and Flash Program I/O	串行总线调试数据 I/O 口 SWD(Serial wire debug) data input and output



## 6. 接口简介 Interfaces Introduction

**注：**以下接口，模块硬件支持，但要和技术确认是否软件支持，默认软件是串口透传，使用 UART TX PB1, RX PB2。如果用到其他接口，请和我司 FAE 确认，必要时建议回传原理图确认。

**Note:**The following interfaces are supported by the module hardware, but the software support shall be confirmed with our technology support. The default software is serial port transparent transmission, using UART TX PB1, RX PB2. If other interfaces are used, please confirm with our FAE. If necessary, it is recommended to send back the schematic diagram for confirmation.

### 6.1 数字输入输出引脚 Digital I/Os

SSB1378A 共有 18 个 GPIO (含 2 个 SWD 调试端口复用 GPIO: PA1\_SWDCCLK, PA2\_SWDDIO)。

SSB1378A has 18 GPIOs (including 2 SWD multiplexed GPIOs: PA1\_SWDCCLK, PA2\_SWDDIO) .

每个 GPIO 引脚可单独配置为输出或输入。可为每个 GPIO 引脚配置更高级的配置，包括开漏、开源和故障过滤。

Each GPIO pin can be individually configured as either an output or input. More advanced configurations including open-drain, open-source, and glitch-filtering can be configured for each individual GPIO pin.

GPIO 引脚可以被外围连接覆盖，如 SPI 通信。每个外围连接都可以路由到设备上的几个 GPIO 引脚。GPIO 引脚的输入值可以通过外围反射系统传送到其他外围设备。GPIO 子系统支持异步外部引脚中断。The GPIO pins can be overridden by peripheral connections, like SPI communication. Each peripheral connection can be routed to several GPIO pins on the device. The input value of a GPIO pin can be routed through the Peripheral Reflex System to other peripherals. The GPIO subsystem supports asynchronous external pin interrupts.

端口 A 和端口 B 上的所有引脚都支持 EM2(EM 解释见备注)。这些引脚可由 EM2/3 中的低能外围设备使用，也可用作 EM2/3 引脚唤醒。端口 C 和 D 上的引脚在进入 EM2 时锁定/保持在其当前状态，直到 EM2 退出，内部外围设备可以再次驱动这些端口。

All of the pins on ports A and port B are EM2 capable (EM explain see note) . These pins may be used by Low-Energy peripherals in EM2/3 and may also be used as EM2/3 pin wake-ups. Pins on ports C and D are latched/retained in their current state when entering EM2 until EM2 exit upon which internal peripherals could once again drive those ports.

一些 GPIO 还具有 EM4 唤醒功能。这些引脚列在备用功能表中。

A few GPIOs also have EM4 wake functionality. These pins are listed in the Alternate Function Table.

GPIO	Alternate Function				
PC00	GPIO.EM4WU6	GPIO.THMSW_EN	GPIO.THMSW_HAL FSWITCH		
PC05	GPIO.EM4WU7				
PC07	GPIO.EM4WU8				
PB03	GPIO.EM4WU4				
PB01	GPIO.EM4WU3				
PB00	IADC0.VREFN				
PA00	IADC0.VREFP				
PA01	GPIO.SWCLK				
PA02	GPIO.SWDIO				
PA03	GPIO.SWW	GPIO.TDO	GPIO.TRACEDA- TA0		
PA04	GPIO.TDI	GPIO.TRACECLK			
PA05	GPIO.EM4WU0				
PD02	GPIO.EM4WU9				
PD01	LFXO.LFXTAL_I	LFXO.LF_EXTCLK			
PD00	LFXO.LFXTAL_O				

**Figure 6: SSB1378A GPIO alternate function**

**注：**EM 指 Energy Mode 低功耗模式。M2/EM3 操作仅端口 A/B 上的数字外设 I/O 支持。EM0 和 EM1 中的数字外设操作所有 GPIO 端口都支持

**Note:** EM stand for Energy Mode. EM2 and EM3 operation is only supported for digital peripheral I/O on Port A and Port B. All GPIO ports support digital peripheral operation in EM0 and EM1.

下表描述了外设功能于特定功耗模式下的实现，其余模块支持完整配置。

The table below describes device specific implementation of the features. Remaining modules support full configuration.

Module	Lowest Energy Mode	Configuration
I2C0	EM2 <sup>1</sup>	
I2C1	EM1	
IADC0	EM2	
LETIMER0	EM2 <sup>1</sup>	
PDM	EM1	2-channel
TIMER0	EM1	32-bit, 3-channels, +DTI
TIMER1	EM1	16-bit, 3-channels, +DTI
TIMER2	EM1	16-bit, 3-channels, +DTI
TIMER3	EM1	16-bit, 3-channels, +DTI
TIMER4	EM1	16-bit, 3-channels, +DTI
EUART0	EM1 - Full high-speed operation EM2 <sup>1</sup> - Low-energy operation, 9600 Baud	
USART0	EM1	+IrDA, +I2S, +SmartCard
USART1	EM1	+IrDA, +I2S, +SmartCard

## 6.2 通用同步/异步接收机/发射机 Universal Synchronous/Asynchronous Receiver/Transmitter

通用同步/异步接收器/发射器是一个灵活的串行 I/O 模块。它支持带硬件流量控制的全双工异步 UART 通信以及 RS-485、SPI、MicroWire 和 3 线。它还可以与支持以下功能的设备连接：ISO7816 SmartCards / IrDA / I2S。

The Universal Synchronous/Asynchronous Receiver/Transmitter is a flexible serial I/O module. It supports full duplex asynchronous UART communication with hardware flow control as well as RS-485, SPI, MicroWire and 3-wire. It can also interface with devices supporting: ISO7816 SmartCards / IrDA / I2S.

## 6.3 两线双向通信接口（兼容 I2C）Two-wire Interface (I2C Compatible)

I2C 模块在 MCU 和串行 I2C 总线之间提供接口。它能够同时充当主总线和从总线，并支持多主总线。支持标准模式、快速模式和快速模式加速度，允许传输速率从 10kbit/s 高达 1Mbit/s。还提供从属仲裁和超时，允许实施符合 SMBus 的系统。I2C 模块为软件提供的接口允许对传输过程进行精确的定时控制和高度自动化的传输。在活动 and 低能模式下提供从机地址的自动识别。请注意，并非所有 I2C 实例在所有能量模式下都是可用的。

The I2C module provides an interface between the MCU and a serial I2C bus. It is capable of acting as both a master and a slave and supports multi-master buses. Standard-mode, fast-mode and fast-mode

plus speeds are supported, allowing transmission rates from 10kbit/s up to 1Mbit/s. Slave arbitration and timeouts are also available, allowing implementation of an SMBus-compliant system. The interface provided to software by the I2C module allows precise timing control of the transmission process and highly automated transfers. Automatic recognition of slave addresses is provided in active and low energy modes. Note that not all instances of I2C are available in all energy modes.

## 6.4 程序烧录口 Flash Program I/Os

SSB1378A有两个烧录管脚，分别是 SWDCLK 和 SWDIO。这个双线串行调试接口提供了一个调试访问接口（DAP），为程序代码的非侵入性调试提供了一个灵活而强大的机制，可以支持断点调试和步进调试。建议设计时留出 4pin 接口（VCC，GND，SWCLK，SWDIO）。

SSB1378A has two programmer pins, respectively SWDCLK pin and SWDIO pin. The two pin Serial Wire Debug (SWD) interface provided as a part of the Debug Access Port (DAP) offers a flexible and powerful mechanism for non-intrusive debugging of program code. Breakpoints and single stepping are part of this support. It is suggested that a 4-pin interface (VCC,GND,SWCLK,SWDIO) should be reserved on your design.

## 6.5 脉冲密度调制接口 Pulse Density Modulation(PDM) Interface

PDM 模块为脉冲密度调制（PDM）话筒、隔离的 Sigma-delta ADC、数字传感器和其他 PDM 或 Sigma-delta 位流外围设备提供串行接口和抽取滤波器。可编程级联积分器梳状（CIC）滤波器用于抽取输入比特流。PDM 支持立体声或单声道输入数据和 DMA 传输。

The PDM module provides a serial interface and decimation filter for Pulse Density Modulation (PDM) microphones, isolated Sigma delta ADCs, digital sensors and other PDM or sigma delta bit stream peripherals. A programmable Cascaded Integrator Comb (CIC) filter is used to decimate the incoming bit streams. PDM supports stereo or mono input data and DMA transfer.

## 6.6 模数转换 Analog to Digital Converter

IADC 是一种混合架构，结合了 SAR 和 Delta-Sigma 转换器的技术。它的分辨率高达 12 位，最高可达 1MSPS。硬件过采样减少了多个前端采样的系统级噪声。空间碎片委员会包括综合电压基准。输入可从多种来源选择，包括可配置为单端或差分的引脚。

The IADC is a hybrid architecture combining techniques from both SAR and Delta-Sigma style converters. It has a resolution of up to 12bits at up to 1MSPS. Hardware oversampling reduces system-level noise over multiple front-end samples. The IADC includes integrated voltage references.

Inputs are selectable from a wide range of sources, including pins configurable as either single-ended or differential.

## 7. 模组参数 Module Specifications

硬件特性/Hardware Features	
模块/Model	SSB1378A
天线类型/Antenna Type	PCB Antenna/ External Antenna(UF.L IPEX-1)
芯片/Chip-set Solution	EFR32BG22
电压/Voltage	1.71V~3.8V
尺寸/Dimension(L×W×H)	19.7×16.5×1.9 mm
无线特性/Wireless Features	
无线标准/Wireless Standards	Bluetooth ® 5.2
频率范围/Frequency Range	2400MHz---2483.5MHz
传输速率/Data Rates	125kbps,500kbps,1Mbps,2Mbps(Bluetooth ® 5.2) 250kbps Proprietary
通讯距离/Communication distance	170m (@+6dBm125kbps,PCB antenna)
广播距离/broadcast distance	50m (+0dBm)
无线安全/Wireless Security	AES HW Encryption
发射功率/Transmit Power	+0dBm to +6dBm(SSB1378)
调制/Modulation	2(G)FSK with fully configurable shaping OQPSK DSSS (G)MSK
接收灵敏度/Receive Sensitivity	-98.9dBm sensitivity @ 1Mbit/s GFSK1 -96.2dBm sensitivity @ 2Mbit/s GFSK -102.5dBm sensitivity @ 500kbps GFSK -106.7dBm sensitivity @ 125kbps GFSK
射频唤醒电平/Wake-on-RF Level	Min -28dBm2(Threshold set to -34dBm)3 Min -23dBm(Threshold set to -28dBm) Min -19dBm(Threshold set to -22dBm)
工作模式/Work Mode	Central/ Peripheral (Master/ Slave device in BLE connection)
功耗参数/Power Consumption	

默认发射功率/Default TX	4.1mA @ 0dBm
默认接收功率/Default RX	3.6mA (1Mbps GFSK)
空闲模式/Idle mode	1.75uA(EM2 Deep Sleep current [32kB RAM retention and RTC running from Precision LFRCO])
发射功耗/Transmit power consumption	10mA (+6dBm)
广播功耗/Broadcast power consumption	28uA (+0dBm,1000ms, connectable)
数据连接功耗/Data connection power consumption	86uA (只连接电流值)
	2.1mA (连接加串口不发数据电流值)
	2.15mA (连接加串口发送数据电流值)
<b>其它/Others</b>	
证明/Certification	ROHS
环境/Environment	Operating Temperature: -40℃~85℃
	Storage Temperature: -40℃~125℃
	Operating Humidity: 10%~50% Non-condensing
	Storage Humidity: 5%~90% Non-condensing

**注 Note :**

1.灵敏度数值为传导测试，接入匹配网络末端。

Values collected with conducted measurements performed at the end of the matching network.

2.可选的唤醒信号采用 1kHz OOK 曼彻斯特编码，8 位前导码，32 位同步字。

Selective wake signal is 1 kHz OOK Manchester-coded, 8 bits of preamble, 32-bit sync word.

**Table9-1: 极限参数 Absolute Maximum Ratings**

Parameter	Condition	Min.	Max.	Unit	Note
Storage Temperature	T <sub>A</sub>	-40	125	°C	
Operating Temperature	T <sub>J</sub>	-40	85	°C	
Humidity	RH	0	50	%	Non-condensing, Non-biased
ESD Protection (HBM)	V <sub>ESD</sub>	TBD	TBD	V	Module pin has no internal ESD protection component. Please put them on the exposed pins (i.e. button, LED directly drive)

Supply Voltage	VCC	-0.3	3.8	V	
Voltage On Any I/O Pin	VCC <sub>IO</sub>	-0.3	VCC+0.3	V	

**Table9-2 推荐参数 Recommended Operation Ratings**

Parameter	Symbol	Min.	Type	Max.	Unit
Power Supply	VCC	1.71	3.3	3.8	V
Input Low Voltage	V <sub>IL</sub>	0	-	0.3*VCC	V
Input High Voltage	V <sub>IH</sub>	0.7*VCC	-	VCC	V
Sink/Source Current per IO pin	I <sub>IO</sub> MAX	-	-	50	mA
Sink/Source Current for all IO pins	I <sub>IO</sub> ALLMAX	-	-	200	mA

## 8. 参考设计原理图 Reference Schematic

模组默认软件使用的参考设计原理图如下。

The reference design schematic diagram used by the default software of the module is as follows.

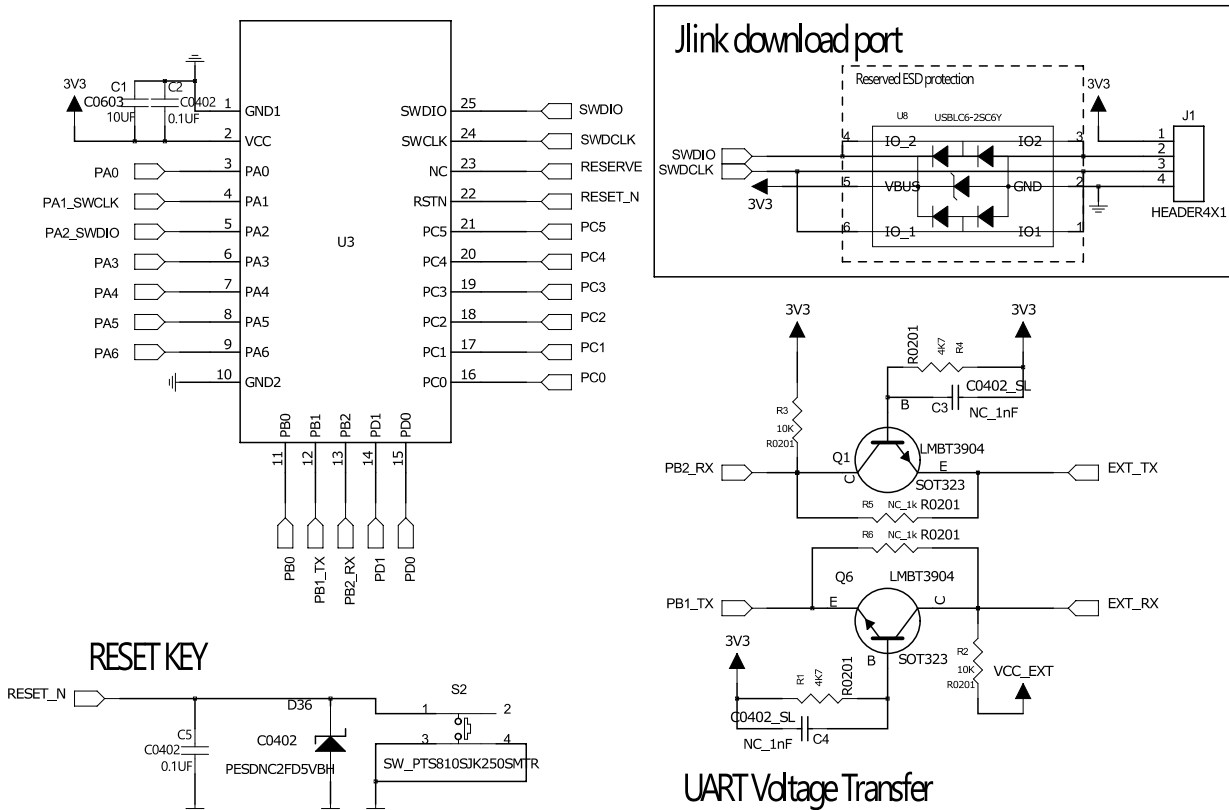

Figure 8 SSB1378A Recommended Schematic

### 注意事项 Note:

1. 模组做 UART 透传的默认串口是 TX\_PB1,RX\_PB2，默认高电平和 VCC 脚的供电电压相同，下图使用了 2 个电平转换电路用作 UART 通信电平的转换，如不需转换使用 R5,R6（小于 1k）替换 Q1,Q6 即可。

The default serial port for UART transparent transmission of the module is TX\_PB1,RX\_PB2. The default voltage high level is the same as the supply voltage of VCC pin. In the figure below, two level conversion circuits are used for the conversion of UART communication level. If it is not necessary, use R5,R6 (less than 1K  $\Omega$ ) instead of Q1, Q6.

2. 建议预留 4pin 的烧录口，方便烧录或者升级软件，烧录口建议预留静电防护器件（可不贴）。



It is recommended to reserve a 4Pin port for firmware downloading or software upgrading. It is recommended to reserve electrostatic protection devices (can be NC) at the burning port.

3. 复位脚内部已经上拉到 VCC，外部无需上拉，如需使用按键复位，请预留防抖动电容，并靠近按键处放置一个 ESD 保护器件。

The reset pin has been pulled up to VCC internally, so there is no need to pull up externally. If you need to use the button to reset, please reserve an anti-shake capacitor and place an ESD protection device near the button.

4. 其余 pin 脚做按键时，建议同复位脚一样预留保护电路，如需做低功耗建议使用外部  $< 2.1M\Omega$  的上拉电阻。

If other pin pins are used as keys, it is recommended to reserve protection circuit same as the reset pin. If low power consumption is required, please use external pull-up resistors ( $< 2.1M\Omega$ ).

5. IO 口驱动能力有限，单个 IO 口驱动电流最大 50mA，所有 IO 口最大电流加起来不得超过 200mA，如需驱动大电流时，请用外部三级管或者 MOS 管驱动。

The current driving capacity of IO port is limited. The maximum driving current of a single IO port is 50mA, and the total maximum current of all IO ports shall not exceed 200mA. If large current needs to be driven, please use external triode or MOFET.

## 9. PCB 设计参考 PCB Design Guide

请为模组的 PCB 天线预留足够的镂空区域，最小镂空尺寸 16.5\*6.6mm，请根据下图 PCB 封装推荐来检查设计。

Please reserve empty area for PCB Antenna when you are going to design a device's board, the empty range minimum size :16.5\*6.6mm , please kindly check the PCB footprint for reference.

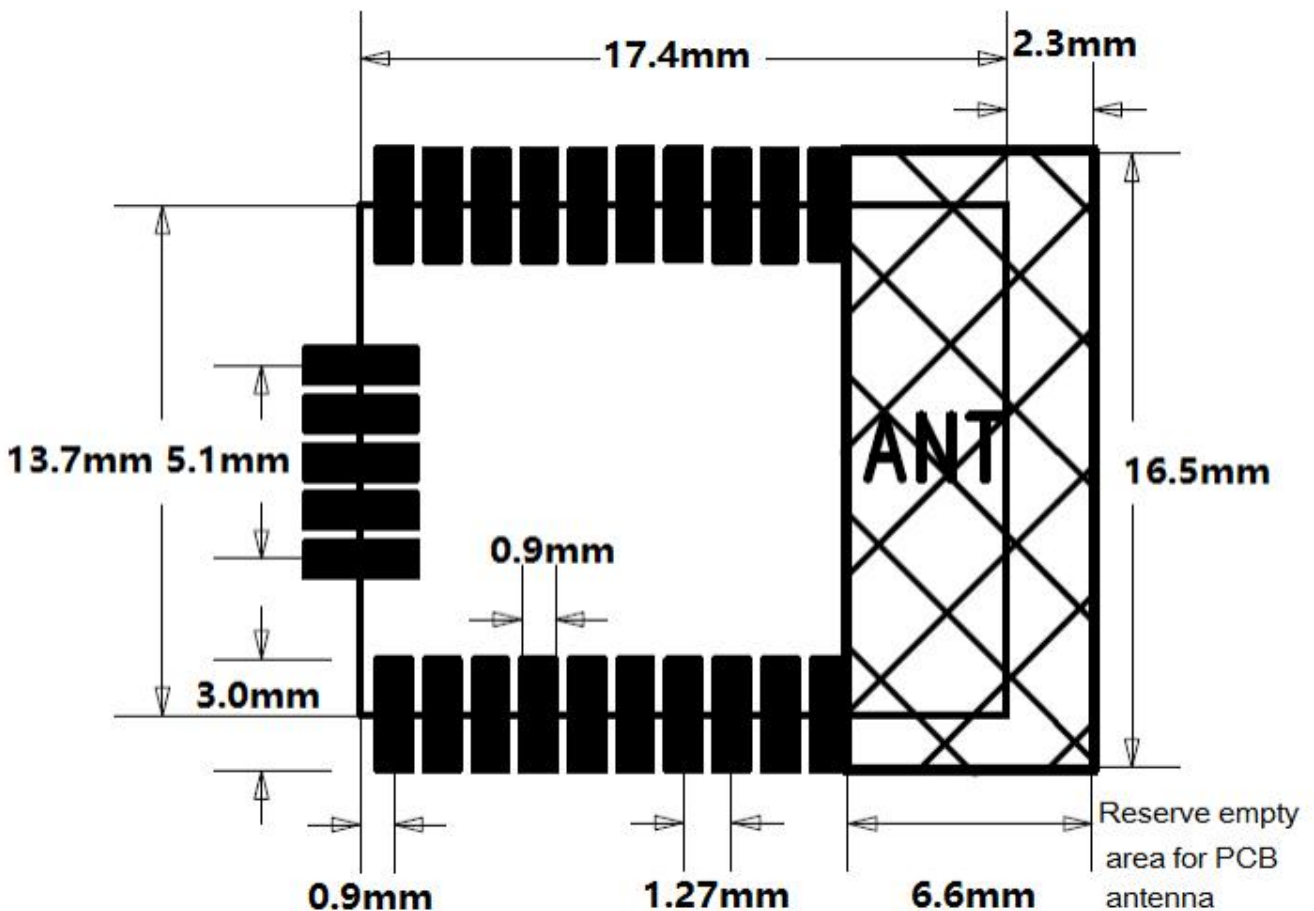

Figure 9 SSB1378A Recommended PCB Footprint

**注：**为加快您的设计，我司可提供标准原理图和 PCB 封装。如有必要，也可以回传设计图请我司技术支持人员确认。

**Note:** In order to speed up your design, we can provide standard schematic diagram and PCB package. If necessary, the design drawing can also be sent back for confirmation by our technical support personnel.

## 10. 生产过程推荐 Manufacturing Process Recommendations

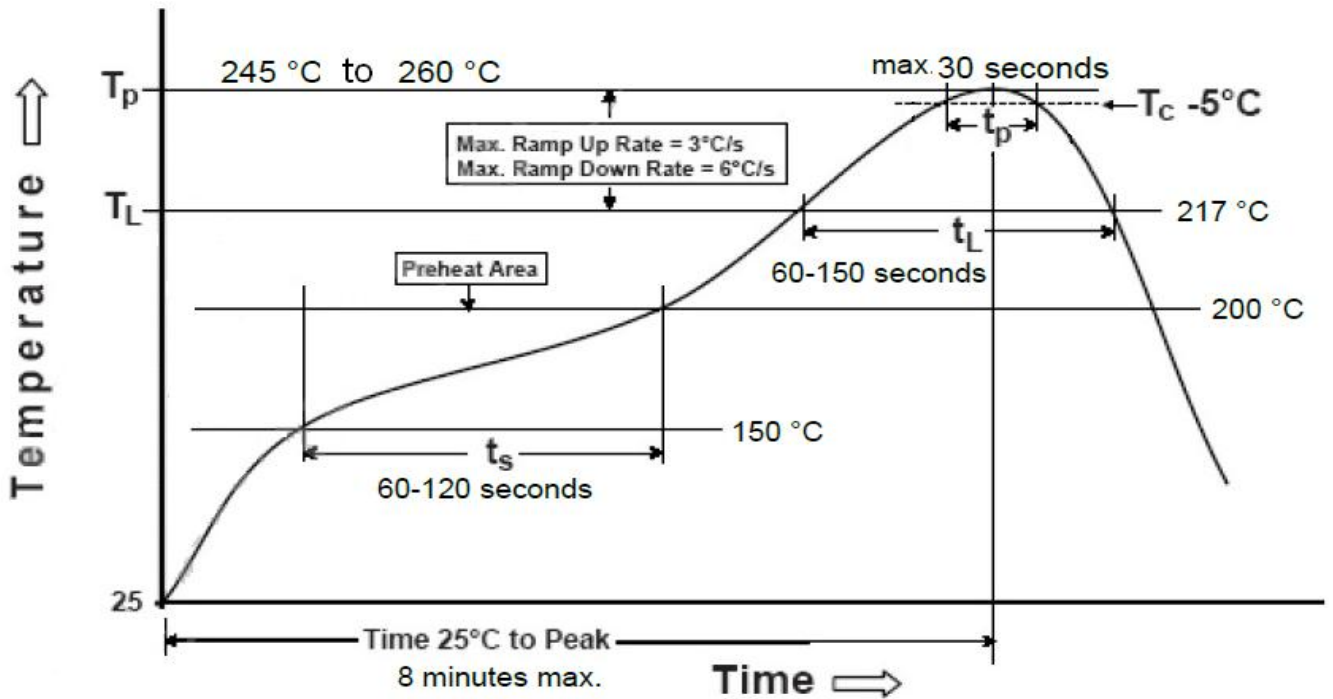

Figure 10: SSB1378A Typical Lead-free Soldering Profile

**注意:**

- 1.最终的炉温曲线取决于工厂的其他因素，如锡膏的种类、尺寸、厚度、模组基板的性质等。
- 2.超出推荐炉温曲线的最高温度可能会损坏模组！

**Note:**

1. The final re-flow soldering temperature map chosen at the factory depends on additional external factors, for example, choice of soldering paste, size, thickness and properties of the module's baseboard etc.
2. Exceeding the maximum soldering temperature in the recommended soldering profile may permanently damage the module!

## 10. 包装信息 Packaging Specification

SSB1378A 模块放入托盘，每个托盘 528 个单元。每个托盘烘干后真空包装。

SSB1378A modules are put into tray and 528 units per tray. Each tray is 'dry' and vacuum packaging.

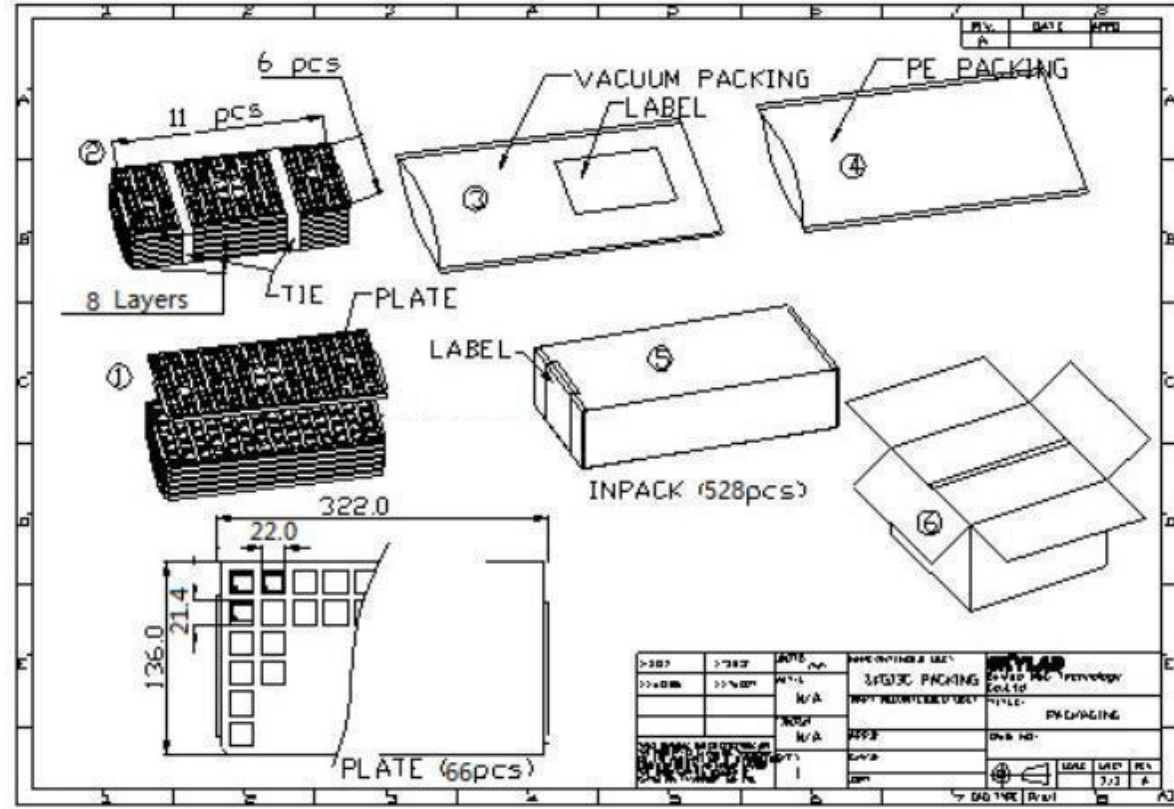

Figure 11: SSB1378A Packaging

## 12. 订购信息 Ordering Information

Module No.	Part number	Product State	Note
SSB1378A-CXPI	0947101	MP	BG22C224,带 32k 晶体_不带屏蔽盖_板载天线_工业级
SSB1378A-CSPI	0947102	Sample	BG22C224,带 32k 晶体_带屏蔽盖_板载天线_工业级
SSB1378A-CXEI	0947103	Sample	BG22C224,带 32k 晶体_不带屏蔽盖_外接天线_工业级
SSB1378A-CSEI	0947104	Sample	BG22C224,带 32k 晶体_带屏蔽盖_外接天线_工业级
SSB1378AA-XXPI	0947105	Sample	BG22C112,不带 32k 晶体_不带屏蔽盖_板载天线_工业级
SSB1378AA-CXPI	0947106	Sample	BG22C112,带 32k 晶体_不带屏蔽盖_板载天线_工业级
SSB1378AA-CSPI	0947107	Sample	BG22C112,带 32k 晶体_带屏蔽盖_板载天线_工业级

## 尾缀含义 Sub-fix definition

## SSB1378(A)-1234

字符位置/Character position	值/Value	含义/Meaning
(A)	-	SSB1378A默认使用 BG22C224
	A	SSB1378A使用 BG22C112
1	C	支持 32.768kHz 晶体 32.768kHz Crystal support
	X	不支持 Not support
2	S	支持屏蔽盖 Sheild cover support
	X	不支持屏蔽盖 Not support
3	P	支持 PCB 天线 PCB antenna
	E	外置天线 External antenna (IPEX-III)
4	C	商用级 Commercial(0~70℃)
	I	默认工业级=CIIndustrial(-40~85℃)
	V	车规级 Vehicle(-40~125℃) (需定制)

部分型号暂未批量，如有需要请联系业务员。

Some models aren't in mass production, please contact the salesman if necessary.