

Features

- Wide Input Voltage Range 4.5V to 60V
- 60V / 0.9Ω Internal Power MOSFET
- 600mA Peak Output Current
- Up to 90% Efficiency
- 1.25MHz (HT7463C) and 550kHz (HT7463D) Fixed Operating Frequency
- Ultra Low Shutdown Current < 1μA
- Output Short Circuit Protection
- Thermal Shutdown Protection
- Package Type: 6-pin SOT23

Applications

- Power Meters
- Distribution Power Systems
- Battery Chargers
- Pre-Regulator for Linear Regulators

General Description

The HT7463C/D is a current mode buck converter. With a wide input range from 4.5V to 60V, the HT7463C/D is suitable for a wide range of applications such as power conditioning from unregulated sources. Having a low internal switch typical $R_{DS(ON)}$ value of 0.9Ω, the device has a good operating typical efficiency value of 85% and the added advantage of reduced junction temperature. The operating frequency is fixed at 1250/550kHz for the HT7463C/HT7463D respectively. The HT7463C allows the use of small external components while still being able to have low output voltage ripple. A soft-start function can be implemented using the enable pin and by connecting an external RC circuit allowing the user to tailor the soft-start time to a specific application.

Application Circuit

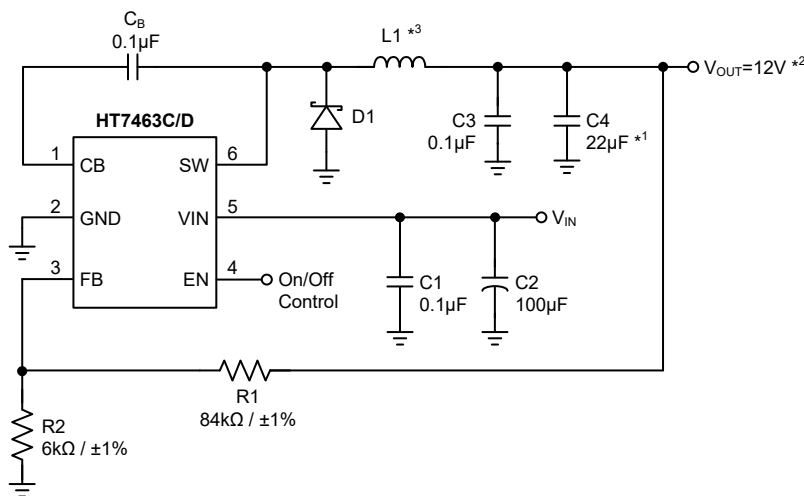

Note: *1. C4=330μF is recommended to achieve 1% output ripple requirement

*2. Set R1=84kΩ and R2=6kΩ for $V_{OUT}=12V$ application

*3. Typically recommended that L1=22μH for HT7463C and L1=47μH for HT7463D. Electromagnetic interference situation suggest L1=100μH or more

Block Diagram

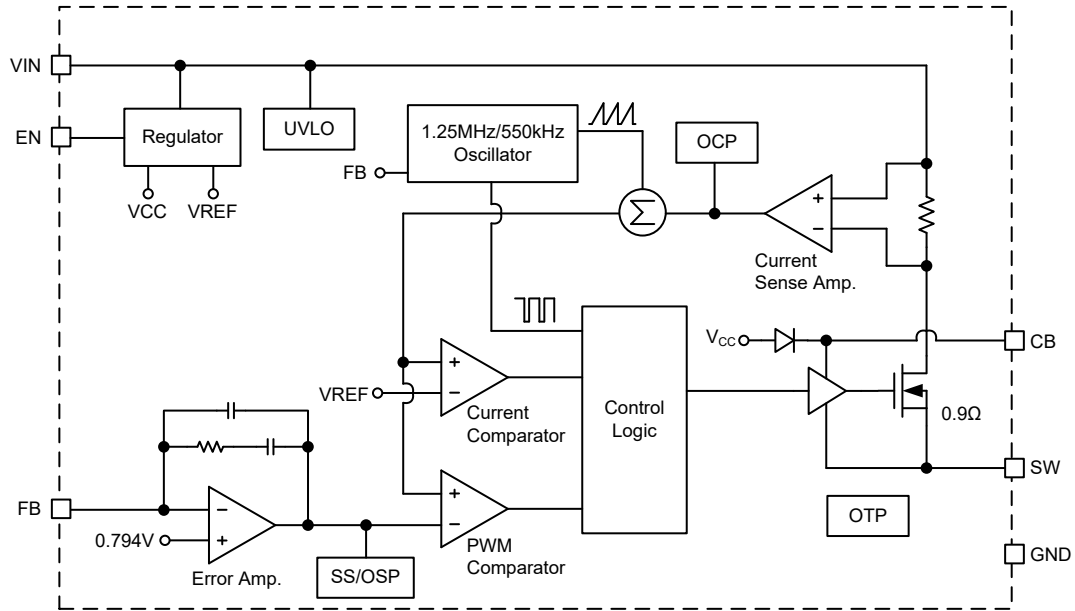

Pin Assignment

SOT23-6

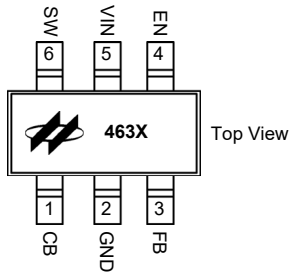

X means C(1.25MHz)/or D(550kHz)

Pin Description

| Pin Order | Name | Type | Pin Discription |
|-----------|------|------|--|
| 1 | CB | I/O | SW FET gate bias voltage. Connect the boot capacitor between CB and SW |
| 2 | GND | G | Ground terminal |
| 3 | FB | I | Feedback pin: Set feedback voltage divider ratio with $V_{OUT} = V_{FB} (1+(R1/R2))$ |
| 4 | EN | I | Logic level shutdown pin. Internal pull low resistor |
| 5 | VIN | P | Power supply |
| 6 | SW | O | Power FET output |

Absolute Maximum Ratings

| Parameter | Value | Unit |
|---|-------------------|------|
| VIN and SW | -0.3 to 66 | V |
| EN | -0.3 to (VIN+0.3) | V |
| CB above SW voltage | +5.5 | V |
| FB | -0.3 to 5.0 | V |
| Operating Temperature Range | -40 to 85 | °C |
| Maximum Junction Temperature | 150 | °C |
| Storage Temperature Range | -60 to 150 | °C |
| Lead Temperature (Soldering 10sec) | 300 | °C |
| ESD Susceptibility | Human Body Model | 5000 |
| | Machine Model | 300 |
| Junction-to-Ambient Thermal Resistance, θ_{JA} | 220 | °C/W |
| Junction-to-Case Thermal Resistance, θ_{JC} | 110 | °C/W |

Recommended Operating Range

| Parameter | Value | Unit |
|-----------|-----------|------|
| VIN | 4.5 to 60 | V |
| SW and EN | Up to 60 | V |

Note: Absolute Maximum Ratings indicate limitations beyond which damage to the device may occur. Recommended Operating Ratings indicate conditions for which the device is intended to be functional, but do not guarantee specified performance limits.

Electrical Characteristics

 $V_{IN}=12V$ and $T_a=+25^{\circ}C$, unless otherwise specified

| Symbol | Parameter | Test Condition | Min | Typ | Max | Unit |
|-----------------------|-----------------------------------|------------------------------------|-------|-------|---------------------|-------------|
| Supply Voltage | | | | | | |
| V_{IN} | Input Voltage | V_{IN} | 4.5 | — | 60 | V |
| I_{CC} | Quiescent Current | $V_{EN}=2.5V, V_{FB}=1V$ | — | 0.5 | 0.6 | mA |
| I_{OFF} | Shutdown Current | $V_{EN}=0V$ | — | 0.1 | 1 | μA |
| Buck Converter | | | | | | |
| V_{OUT} | Output Voltage ^(Note) | — | 1.0 | — | $0.9 \times V_{IN}$ | V |
| f_{SW} | Switching Frequency | HT7463C, $V_{FB}=0.6V$ | 1000 | 1250 | 1500 | kHz |
| | | HT7463D, $V_{FB}=0.6V$ | 440 | 550 | 660 | kHz |
| F_{FB} | Fold-back Frequency | HT7463C, $V_{FB}=0V$ | 85 | 105 | — | kHz |
| | | HT7463D, $V_{FB}=0V$ | 85 | 105 | — | kHz |
| D_{MAX} | Maximum Duty Cycle | HT7463C | — | 90 | — | % |
| | | HT7463D | — | 95 | — | % |
| $T_{ON(min)}$ | Minimum ON-Time | — | — | 100 | — | ns |
| $R_{DS(on)}$ | Switch-ON Resistance | $V_{EN}=2.5V$ | — | 0.9 | — | Ω |
| I_{SW} | SW Leakage Current | $V_{EN}=0V, V_{SW}=0V, V_{IN}=60V$ | — | 0.1 | 1 | μA |
| V_{FB} | Feedback Voltage | $4.5V \leq V_{IN} \leq 60V$ | 0.778 | 0.794 | 0.81 | V |
| $I_{FB(leak)}$ | Feedback Leakage Current | $V_{FB}=3V$ | — | — | 0.1 | μA |
| I_{EN} | EN Input Current | $V_{EN}=0V$ | — | 0.1 | — | μA |
| | | $V_{EN}=60V$ | — | 16 | — | μA |
| V_{IH} | EN High Voltage Threshold | $4.5V \leq V_{IN} \leq 60V$ | 2.3 | — | — | V |
| V_{IL} | EN Low Voltage Threshold | $4.5V \leq V_{IN} \leq 60V$ | — | — | 0.9 | V |
| Protections | | | | | | |
| V_{UVLO+} | Input Supply Turn ON Level | UVLO+ | — | — | 4.2 | V |
| V_{UVLO-} | Input Supply Turn OFF Level | UVLO- | 3.4 | — | — | V |
| I_{OCP} | Over Current Protection Threshold | — | — | 1.2 | — | A |
| T_{SHD} | Thermal Shutdown Threshold | OTP | — | 150 | — | $^{\circ}C$ |
| T_{REC} | Thermal Recovery Temperature | — | — | 125 | — | $^{\circ}C$ |

Note: 1. MIN Output Voltage is restricted by Minimum ON-Time, 100ns.

2. MAX Output Voltage is restricted by Maximum Duty Cycle and Switch-ON Resistance.

3. The selection use of the HT7463C/HT7463D can refer to the Recommended Operating Area.

Typical Performance Characteristics

$V_{IN}=18V$, $V_{OUT}=12.5V$, $L=15/22\mu H$ for HT7463C and $L=33/47\mu H$ for HT7463D, $T_a=25^\circ C$, unless otherwise noted

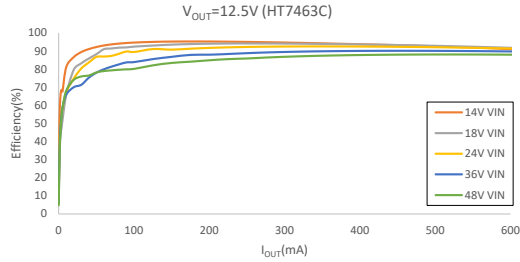

Efficiency vs. Load (HT7463C, $V_{OUT}=12.5V$)

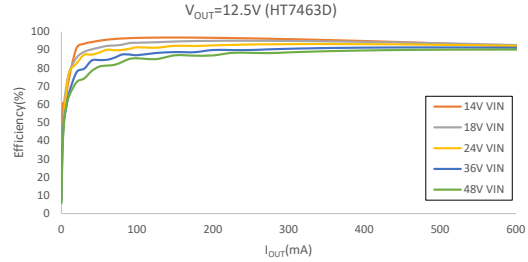

Efficiency vs. Load (HT7463D, $V_{OUT}=12.5V$)

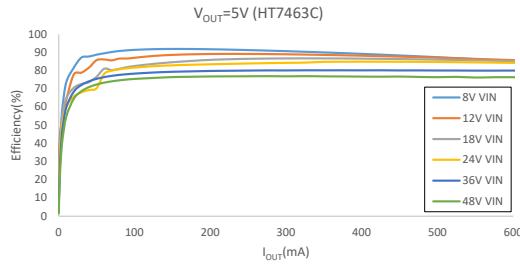

Efficiency vs. Load (HT7463C, $V_{OUT}=5V$)

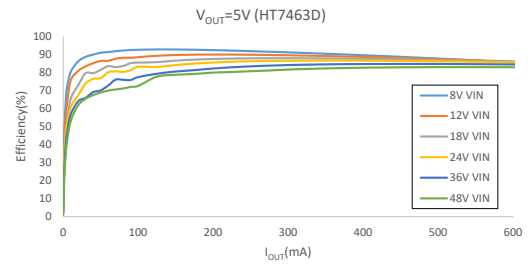

Efficiency vs. Load (HT7463D, $V_{OUT}=5V$)

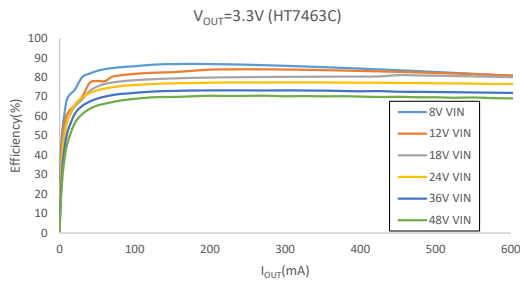

Efficiency vs. Load (HT7463C, $V_{OUT}=3.3V$)

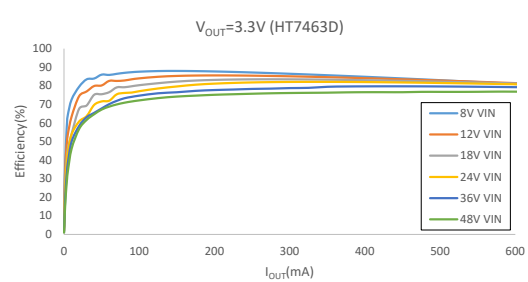

Efficiency vs. Load (HT7463D, $V_{OUT}=3.3V$)

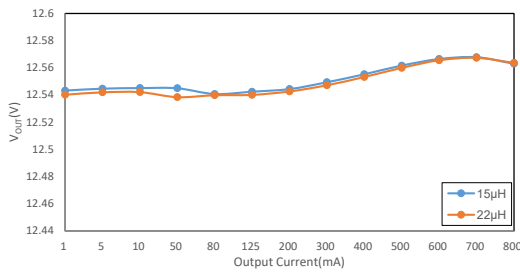

Load Regulation (HT7463C, $V_{OUT}=12.5V$)

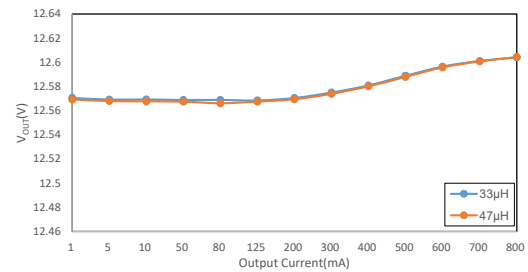

Load Regulation (HT7463D, $V_{OUT}=12.5V$)

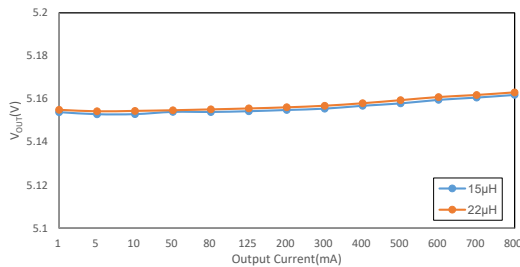

Load Regulation (HT7463C, $V_{OUT}=5V$)

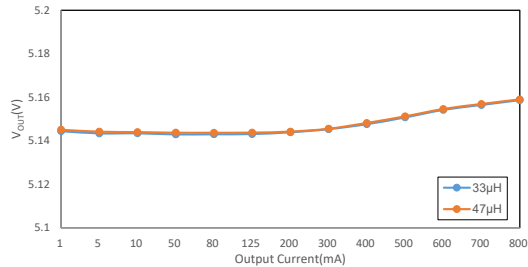

Load Regulation (HT7463D, $V_{OUT}=5V$)

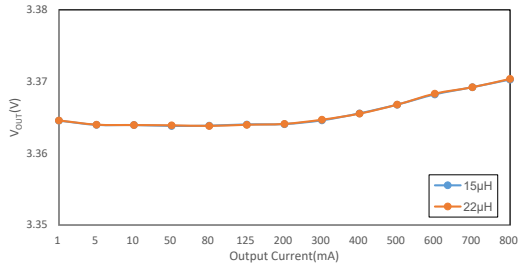

Load Regulation (HT7463C, V_{OUT}=3.3V)

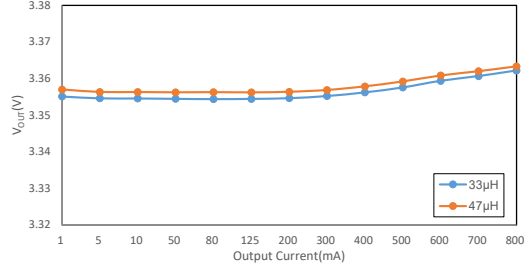

Load Regulation (HT7463D, V_{OUT}=3.3V)

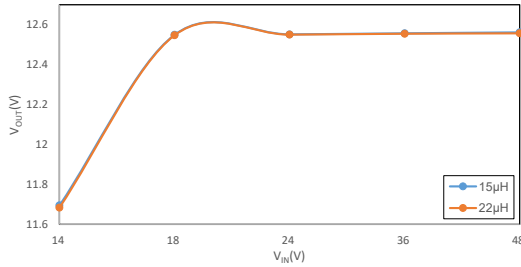

Line Regulation (HT7463C, V_{OUT}=12.5V, I_{OUT}=300mA)

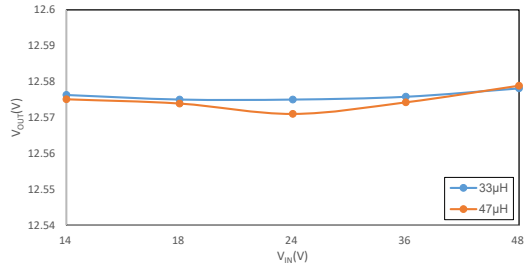

Line Regulation (HT7463D, V_{OUT}=12.5V, I_{OUT}=300mA)

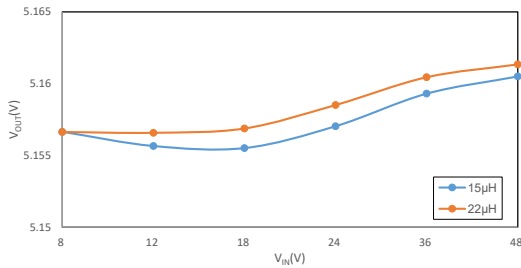

Line Regulation (HT7463C, V_{OUT}=5V, I_{OUT}=300mA)

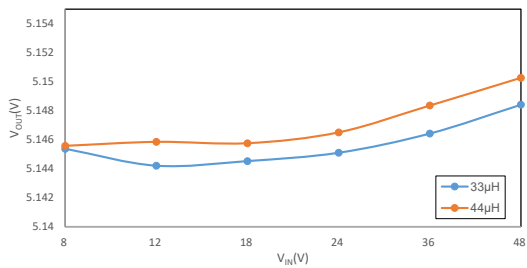

Line Regulation (HT7463D, V_{OUT}=5V, I_{OUT}=300mA)

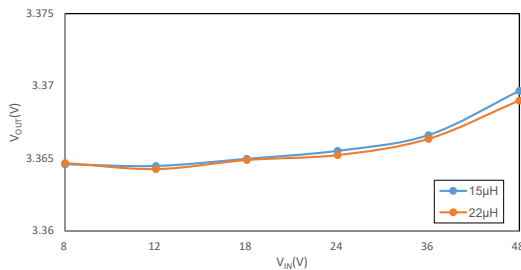

Line Regulation (HT7463C, V_{OUT}=3.3V, I_{OUT}=300mA)

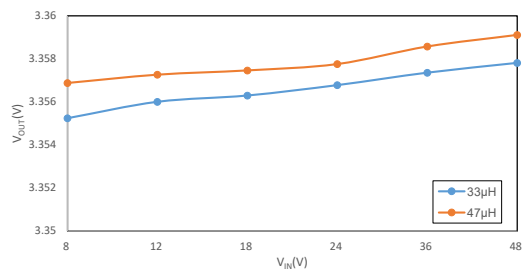

Line Regulation (HT7463D, V_{OUT}=3.3V, I_{OUT}=300mA)

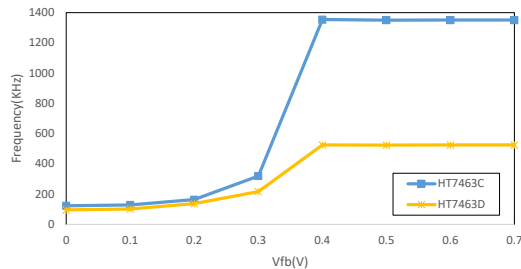

f_{SW} vs. V_{FB} (HT7463C and HT7463D)

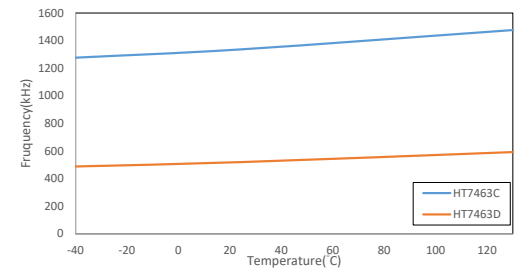

f_{SW} vs. Temp. (HT7463C and HT7463D)

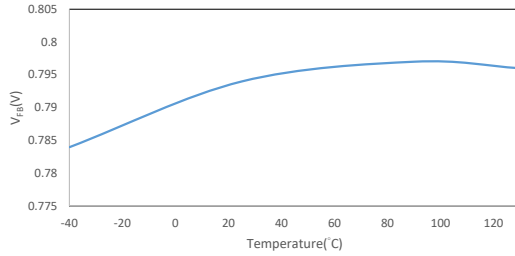

V_{FB} vs. Temp. (HT7463CD)

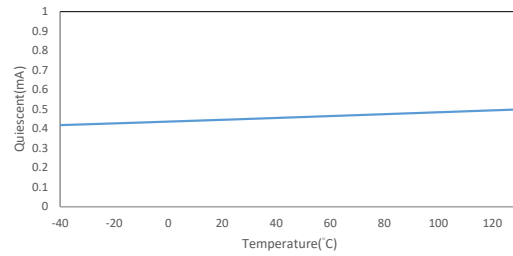

I_{CC} vs. Temp. (HT7463CD)

Typical Performance Characteristics (Continued)

$V_{IN}=18V$, $V_{OUT}=12.5V$, $L=22\mu H$ for HT7463C and $L=47\mu H$ for HT7463D, $T_a=25^\circ C$, unless otherwise noted

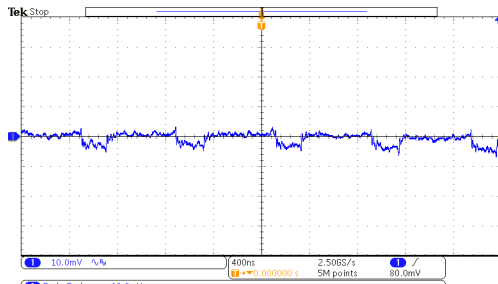

Output Ripple (HT7463C, $I_{OUT}=400mA$)

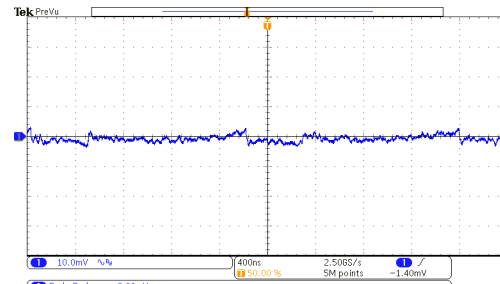

Output Ripple (HT7463D, $I_{OUT}=400mA$)

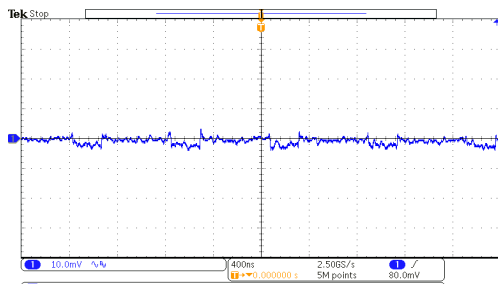

Output Ripple (HT7463C, $I_{OUT}=125mA$)

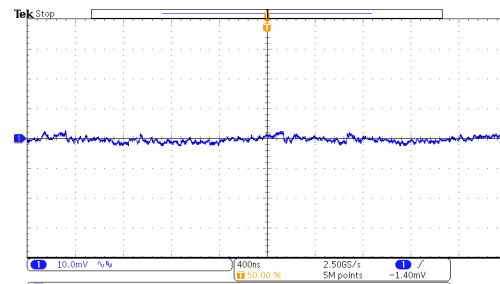

Output Ripple (HT7463D, $I_{OUT}=125mA$)

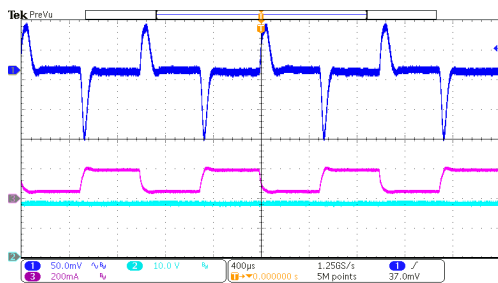

Load Transient (HT7463C, $I_{OUT}=50mA\sim 200mA$)

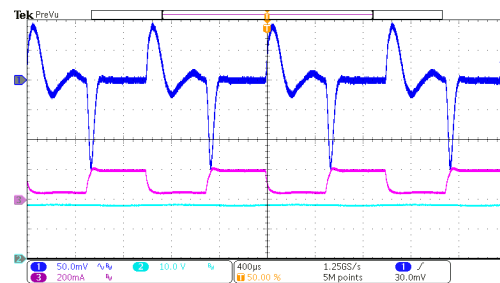

Load Transient (HT7463D, $I_{OUT}=50mA\sim 200mA$)

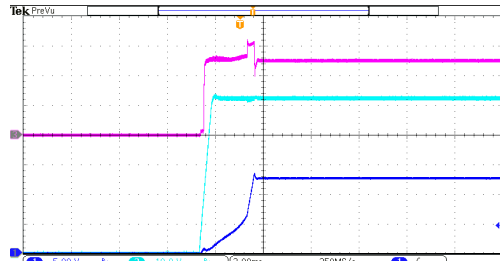

Power Up (HT7463C, $V_{IN}=52V$, $I_{OUT}=500mA$)

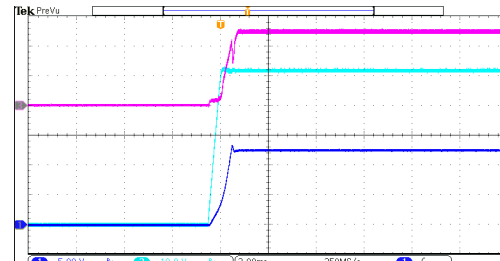

Power Up (HT7463D, $V_{IN}=52V$, $I_{OUT}=500mA$)

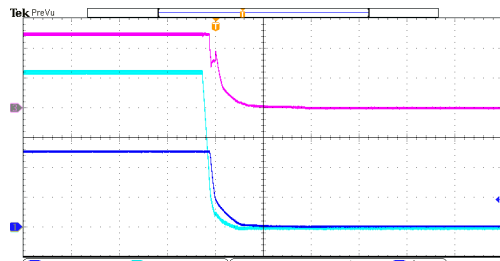

Power Down (HT7463C, $V_{IN}=52V$, $I_{OUT}=500mA$)

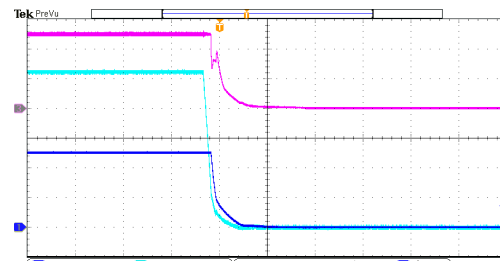

Power Down (HT7463D, $V_{IN}=52V$, $I_{OUT}=500mA$)

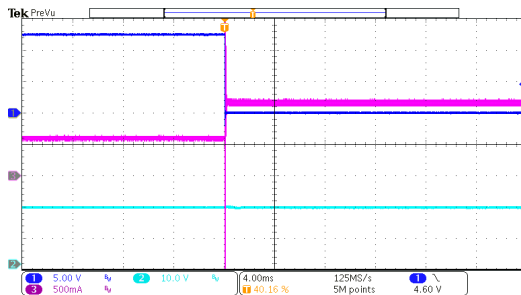

Output Short (HT7463C, $I_{OUT}=500mA$)

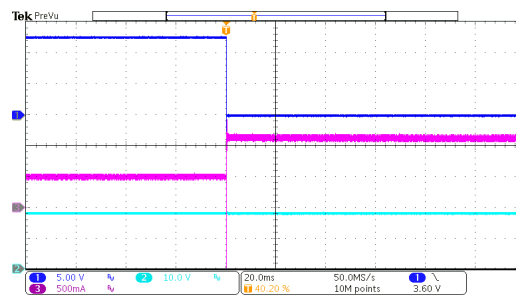

Output Short (HT7463D, $I_{OUT}=500mA$)

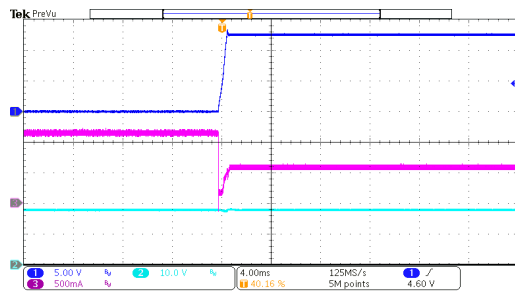

Short Recovery (HT7463C, $I_{OUT}=500mA$)

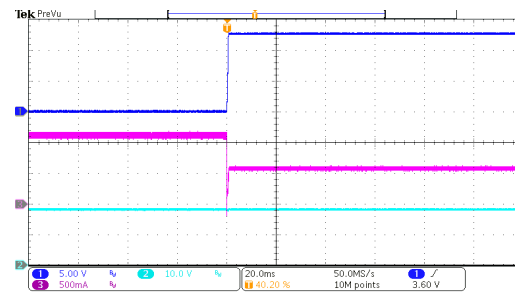

Short Recovery (HT7463D, $I_{OUT}=500mA$)

Functional Description

Output Voltage Setup

The external resistor divider sets the output voltage, for details see the Application Circuit. The feedback resistor, R1, also sets the feedback loop bandwidth with the internal compensation capacitor. R2 is calculated using the following equation:

$$R2=R1/((V_{OUT}/0.794V)-1) \Omega$$

Protection Features

The devices include dedicated protection circuitry which is fully active during normal operation for full device protection. The thermal shutdown circuitry turns off power to the device when the die temperature reaches excessive levels. The UVLO comparator protects the power device during supply power startup and shutdown to prevent operation at voltages less than the minimum input voltage. The HT7463C/D also features a shutdown mode decreasing the supply current to approximately 0.1μA.

| Protection | Trigger | V _{OUT} | Recovery |
|-----------------------------------|--|---|--|
| Under Voltage Lockout (UVLO) | V _{IN} is lower than V _{UVLO-} | V _{OUT} is 0V | V _{IN} is higher than V _{UVLO+} |
| Over Current Protection (OCP) | I _L rises to I _{OCP} | V _{OUT} drop depends on duty cycle | I _L is lower than I _{OCP} next cycle |
| Fold-back Frequency | V _{FB} is lower than 0.5V | V _{OUT} drops | V _{FB} rises to 0.5V |
| Over Temperature Protection (OTP) | T _j is over T _{SHD} | V _{OUT} drops to 0V | T _j decreases to T _{REC} |

Recommended Operating Area

The recommended operating area is related to the frequency, minimum on time, minimum off time, over current and stability. The selection of the HT7463C/HT7463D can be implemented by referring the following Recommended Operating Area figure according to input/output voltage requirements. For example, if the input voltage is 30V and the output voltage is 5V, V_{OUT}/V_{IN}=5V/30V=16.67%, refer to the figure below, Y-axis V_{IN} is 30V, HT7463D is recommended. If the input voltage minus the output voltage is lower than 2.5V and no load, refer to Component Selection for Low input & No-load to adjust the feedback resistor value.

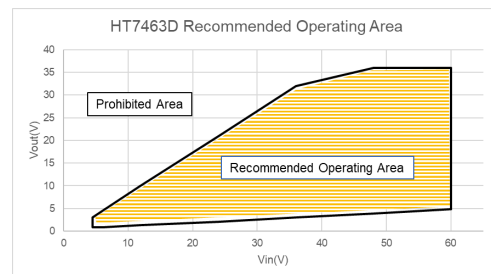
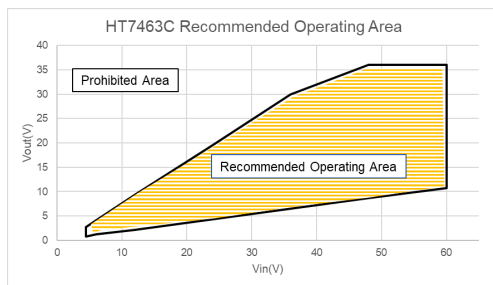

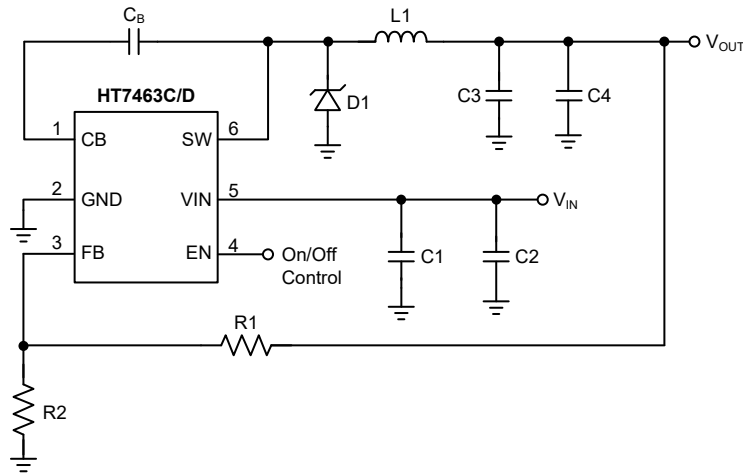
Recommended Component Values

Component Recommended Values

| V_{OUT} (V) | Package | R1 (k Ω) | R2 (k Ω) |
|---------------|----------|------------------|-------------------|
| 3.3 | SMD 0603 | 51 ($\pm 1\%$) | 16 ($\pm 1\%$) |
| 5.0 | | 82 ($\pm 1\%$) | 15 ($\pm 1\%$) |
| 12.5 | | 91 ($\pm 1\%$) | 6.2 ($\pm 1\%$) |

| Reference | Package | Description | Part Number | Mfgr. |
|-----------|-------------------------------------|--------------------------------|-----------------------|------------|
| C1 | SMD 0603 | CAP 0.1 μ F/50V | GRM188R71H104JA93D | Murata |
| C2 | DIP | 68 μ F/63V | LGK Series | Liket Corp |
| C3 | SMD 0603 | CAP 0.1 μ F/50V | GRM188R71H104JA93D | Murata |
| C4 | DIP | 47 μ F/25V | LGK Series | Liket Corp |
| CB | SMD 0603 | CAP 0.1 μ F/50V | GRM188R71M104K9 | Murata |
| L1 | 5.8mm \times 5.2mm \times 4.5mm | HT7463C: 15 μ H/22 μ H | GS54-150K / GS54-220K | Gang Song |
| | | HT7463D: 33 μ H/47 μ H | GS54-330K / GS54-470K | |
| D1 | DO-214AC | Schottky Rectifier | SS16 | Fairchild |

Frequency Fold-back Function

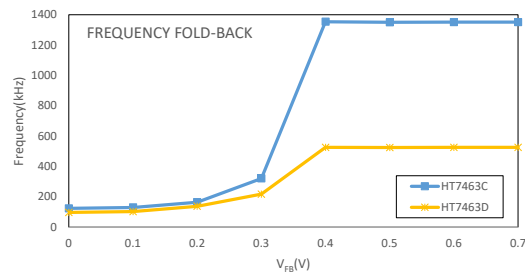
The devices include a frequency fold-back function to prevent situations of over current when the output is shorted. It efficiently reduces overheating even if the output is shorted. This function is implemented by changing the switching frequency according to the feedback voltage, V_{FB} . When the output node is shorted, the device will reduce the frequency to 105kHz for the HT7463C/HT7463D respectively resulting in a clamped input current. The HT7463C/HT7463D operates at a frequency of 1250/550kHz under normal conditions and the feedback voltage is about 0.794V.



Start-up Function

The device EN pin in conjunction with an RC filter is used to tailor the soft-start time to specific application requirements. When a voltage applied to the EN pin is between 0V and 2.3V, the device will cause the cycle-by-cycle current limit in the power stage to be modulated for a minimum current limit at 0V up to a the rated current limit at 2.3V. Thus, the output rise time and inrush current at startup are controlled.

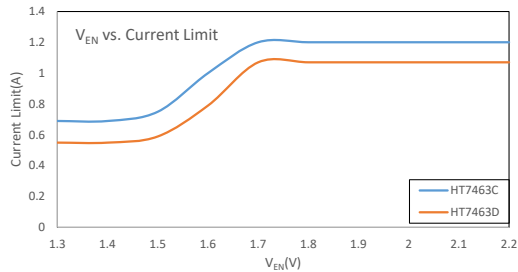

Component Selection Guide

Inductor

Use an inductor with a DC current rating at least 25% percent higher than the maximum load current for most applications. The DC resistance of the inductor is a key parameter affecting efficiency. With regard to efficiency, the inductor's DC resistance should be less than 200m Ω . For most application, the inductor value can be calculated from the following equation.

$$L = \frac{V_{out} \times (V_{IN} - V_{out})}{V_{IN} \times I_{ripple} \times f_{sw}}$$

A higher value of ripple current reduces the inductance value, but increases the conductance loss, core loss, and current stress for the inductor and switch devices. A suggested choice is for the inductor ripple current to be 30% of the maximum load current.

If some electromagnetic interference situation, suggest inductor value 100 μ H or more.

Input Capacitor

A low ESR ceramic capacitor (CIN) is needed between the VIN pin and GND pin. Use ceramic capacitors with X5R or X7R dielectrics for their low ESRs and small temperature coefficients. For most applications, a 2.2 μ F- 10 μ F capacitor will suffice.

Output Capacitor

The selection of COUT is driven by the maximum allowable output voltage ripple. Use ceramic capacitors with X5R or X7R dielectrics for their low ESR characteristics. Capacitors in the range of 22 μ F to 100 μ F are a good starting point with an ESR of 0.1 Ω or less.

330 μ F is recommended to achieve 1% output ripple requirement.

Schottky Diode

The breakdown voltage rating of the diode should be higher than the maximum input voltage. The current rating for the diode should be equal to the maximum output current to ensure the best reliability in most applications. In this case it is possible to use a diode with a lower average current rating, however the peak current rating should be higher than the maximum load current.

Bootstrap Capacitor

A 0.1 μ F ceramic capacitor or larger is recommended for the bootstrap capacitor. Generally a 0.1 μ F to 1 μ F value can be used to ensure sufficient gate drive for the internal switches and a consistently low $R_{DS(on)}$.

Layout Consideration Guide

To reduce problems with conducted noise, there are some important points to consider regarding the PCB layout.

- Ensure all feedback connections are short and direct. Place the feedback resistors and compensation components as close to the FB pin as possible.
- The input bypass capacitor must be placed close to the VIN pin.
- The inductor, schottky diode and output capacitor trace should be as short as possible to reduce conducted and radiated noise and increase overall efficiency.
- Keep the power ground connection as short and wide as possible.

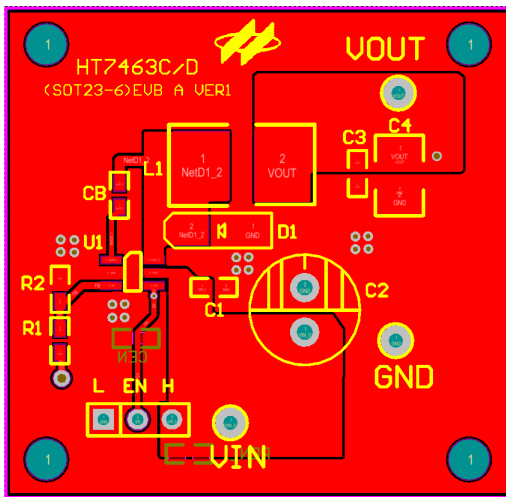

Top View

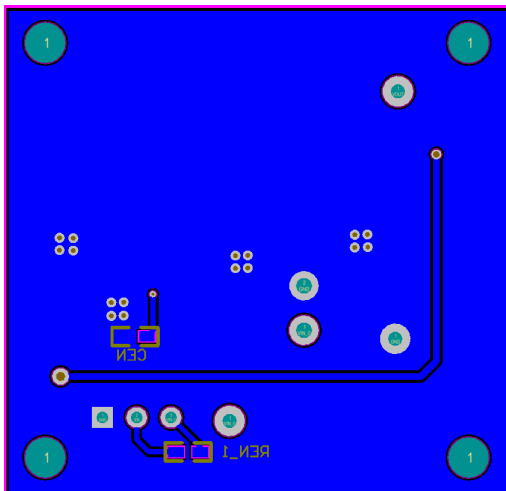

Bottom View

Thermal Considerations

The maximum power dissipation depends on the thermal resistance of the IC package, the PCB layout, the rate of the surrounding airflow and the difference between the junction and ambient temperature. The maximum power dissipation can be calculated by the following formula:

$$P_{D(MAX)} = (T_{J(MAX)} - T_A) / \theta_{JA}$$

where $T_{J(MAX)}$ is the maximum junction temperature, T_A is the ambient temperature and θ_{JA} is the junction-to-ambient thermal resistance of the IC package (220°C/W for 6-pin SOT23)

For maximum operating rating conditions, the maximum junction temperature is 150°C. However, it is recommended that the maximum junction temperature does not exceed 125°C in normal operation to maintain reliability. The derating curve for maximum power dissipation is as follows:

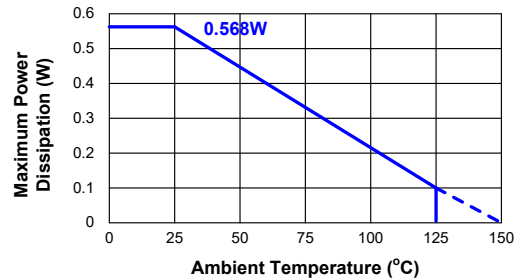

Package Information

Note that the package information provided here is for consultation purposes only. As this information may be updated at regular intervals users are reminded to consult the [Holtek website](#) for the latest version of the [Package/ Carton Information](#).

Additional supplementary information with regard to packaging is listed below. Click on the relevant section to be transferred to the relevant website page.

- Package Information (include Outline Dimensions, Product Tape and Reel Specifications)
- The Operation Instruction of Packing Materials
- Carton information

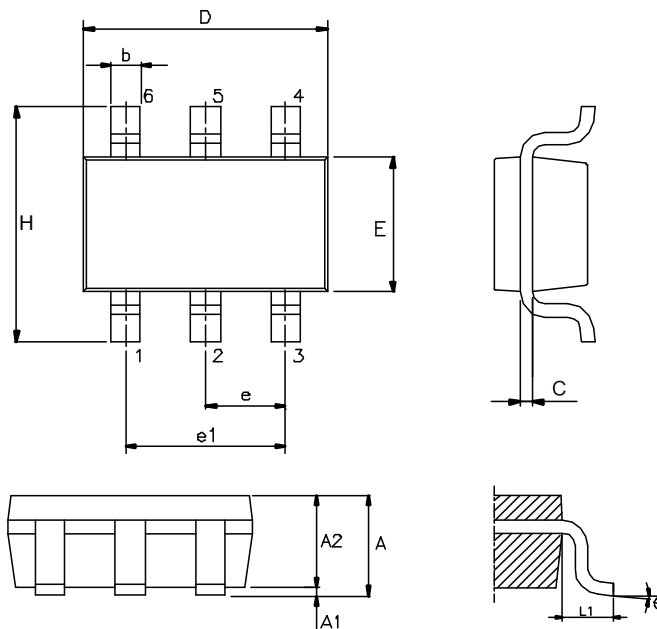
6-pin SOT23 Outline Dimensions

| Symbol | Dimensions in inch | | |
|----------|--------------------|-----------|-------|
| | Min. | Nom. | Max. |
| A | — | — | 0.057 |
| A1 | — | — | 0.006 |
| A2 | 0.035 | 0.045 | 0.051 |
| b | 0.012 | — | 0.020 |
| C | 0.003 | — | 0.009 |
| D | — | 0.114 BSC | — |
| E | — | 0.063 BSC | — |
| e | — | 0.037 BSC | — |
| e1 | — | 0.075 BSC | — |
| H | — | 0.110 BSC | — |
| L1 | — | 0.024 BSC | — |
| θ | 0° | — | 8° |

| Symbol | Dimensions in mm | | |
|----------|------------------|----------|------|
| | Min. | Nom. | Max. |
| A | — | — | 1.45 |
| A1 | — | — | 0.15 |
| A2 | 0.90 | 1.15 | 1.30 |
| b | 0.30 | — | 0.50 |
| C | 0.08 | — | 0.22 |
| D | — | 2.90 BSC | — |
| E | — | 1.60 BSC | — |
| e | — | 0.95 BSC | — |
| e1 | — | 1.90 BSC | — |
| H | — | 2.80 BSC | — |
| L1 | — | 0.60 BSC | — |
| θ | 0° | — | 8° |

Copyright© 2022 by HOLTEK SEMICONDUCTOR INC. All Rights Reserved.

The information provided in this document has been produced with reasonable care and attention before publication, however, HOLTEK does not guarantee that the information is completely accurate. The information contained in this publication is provided for reference only and may be superseded by updates. HOLTEK disclaims any expressed, implied or statutory warranties, including but not limited to suitability for commercialization, satisfactory quality, specifications, characteristics, functions, fitness for a particular purpose, and non-infringement of any third-party's rights. HOLTEK disclaims all liability arising from the information and its application. In addition, HOLTEK does not recommend the use of HOLTEK's products where there is a risk of personal hazard due to malfunction or other reasons. HOLTEK hereby declares that it does not authorize the use of these products in life-saving, life-sustaining or safety critical components. Any use of HOLTEK's products in life-saving/sustaining or safety applications is entirely at the buyer's risk, and the buyer agrees to defend, indemnify and hold HOLTEK harmless from any damages, claims, suits, or expenses resulting from such use. The information provided in this document, including but not limited to the content, data, examples, materials, graphs, and trademarks, is the intellectual property of HOLTEK (and its licensors, where applicable) and is protected by copyright law and other intellectual property laws. No license, express or implied, to any intellectual property right, is granted by HOLTEK herein. HOLTEK reserves the right to revise the information described in the document at any time without prior notice. For the latest information, please contact us.